

Design of Reinforced Concrete Floor Systems

By David A. Fanella, Ph.D., S.E., P.E., and Iyad M. Alsamsam, Ph.D., S.E., P.E.

PROFESSIONAL DEVELOPMENT SERIES

Structural
Engineer



Concrete
Thinking
for a sustainable world



Portland Cement Association



R

einforced concrete floor systems can provide an economical solution to a wide variety of situations. Numerous types of nonprestressed and prestressed floor systems are available to satisfy virtually any span and loading condition, see Figure 1. Selecting the most effective system for a given set of constraints can be vital to achieving overall economy, especially for low- and mid-rise buildings and for buildings subjected to relatively low lateral forces where the cost of the lateral-force-resisting system is minimal.

General considerations

Concrete, reinforcement, and formwork are the three primary expenses in cast-in-place concrete floor construction to consider throughout the design process, but especially during the initial planning stages. Of these three, formwork comprises about 50 to 60 percent of the total cost

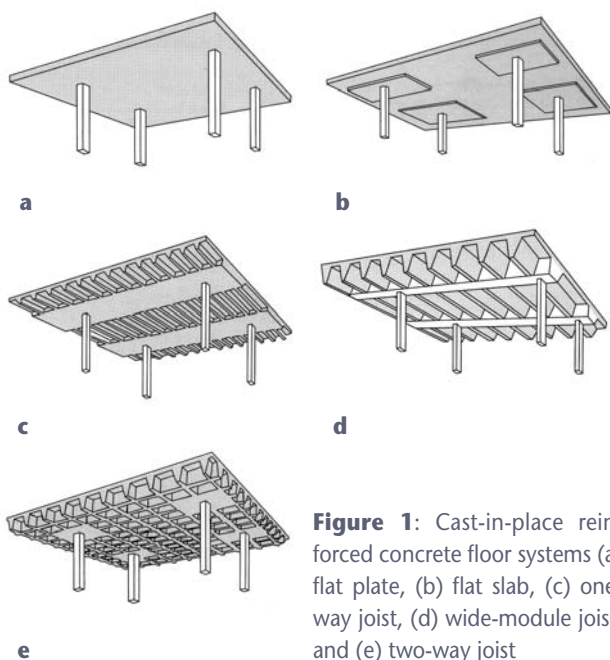

Figure 1: Cast-in-place reinforced concrete floor systems (a) flat plate, (b) flat slab, (c) one-way joist, (d) wide-module joist, and (e) two-way joist

Continuing Education

The Professional Development Series is a unique opportunity to earn continuing education credit by reading specially focused, sponsored articles in **Structural Engineer**. If you read the following article, display your understanding of the stated learning objectives, and follow the simple instructions, you can fulfill a portion of your continuing education requirements at no cost to you.

Instructions

First, review the learning objectives below, then read the Professional Development Series article. Next complete the quiz and submit your answers to the Professional Development Series sponsor. Submittal instructions are provided on the Reporting Form, which follows the quiz and is also available for download at www.gostructural.com/se-pdh.

Your quiz answers will be graded by the Professional Development Series sponsor. If you answer at least 80 percent of the questions correctly, you will receive a certificate of completion from the Professional Development Series sponsor within 90 days and will be awarded 2.0 professional development hour (equivalent to 0.2 continuing education unit in most states).

Note: It is the responsibility of the licensee to determine if this method of continuing education meets his or her governing board(s) of registration's requirements.

Learning Objectives

This tutorial focuses on cast-in-place concrete floor systems with nonprestressed reinforcement. The reader will learn methods of analysis and design for these types of floor systems that satisfy The American Concrete Institute's Building Code Requirements for Structural Concrete (ACI 318-05). All referenced items are from ACI 318-05, unless noted otherwise.

Professional Development Series Sponsor Portland Cement Association

and has the greatest influence on the overall cost of the floor system. The cost of the concrete, including placing and finishing, typically accounts for about 25 to 30 percent of the overall cost. The reinforcing steel has the lowest influence on overall cost.

To achieve overall economy, designers should satisfy the following three basic principles of formwork economy:

Specify readily available standard form sizes. Rarely will custom forms be economical, unless they are required in a quantity that allows for mass production.

Repeat sizes and shapes of the concrete members wherever possible. Repetition allows reuse of forms from bay to bay and from floor to floor.

Strive for simple formwork. In cast-in-place concrete construction, economy is rarely achieved by reducing quantities of materials. For example, varying the depth of a beam



with the loading and span variations would give a moderate savings in materials, but would create substantial additional costs in formwork, resulting in a more expensive structure. The simplest and most cost-effective solution would be providing a constant beam depth and varying the reinforcement along the span. Simple formwork can make construction time shorter, resulting in a building that can be occupied sooner.

Additional parameters must be considered when selecting an economical floor system. In general, span lengths, floor loads, and geometry of a floor panel all play a key role in the selection process. Detailed information on how to select economical concrete floor systems for a wide variety of situations can be found in the following Portland Cement Association (PCA) publications: Concrete Floor Systems — Guide to Estimating and Economizing (SP041), and Long-Span Concrete Floor Systems (SP339).

Preliminary sizing

Before analyzing the floor system, designers must assume preliminary member sizes. Typically, the slab and/or beam thickness is determined first to ensure that the deflection requirements of Section 9.5 are satisfied.

For solid, one-way slabs and beams that are not supporting or attached to partitions or other construction likely to be damaged by large deflections, Table 9.5(a) may be used to determine minimum thickness, h . For continuous one-way slabs and beams, determine h based on one end continuous, since this thickness will satisfy deflection criteria for all spans. The preliminary thickness of a solid one-way slab with normal weight concrete and Grade 60 reinforcement is $\ell/24$, where ℓ is the span length in inches. Similarly, for beams, minimum h is $\ell/18.5$. Deflections need not be computed when a thickness at least equal to the minimum is provided.

For nonprestressed, two-way slabs, minimum thickness requirements are given in Section 9.5.3. By satisfying these minimum requirements, which are illustrated in Figure 2 for Grade 60 reinforcement, deflections need not be computed. Deflection calculations for two-way slabs are complex, even when linear elastic behavior is assumed. In Figure 2, α_f is the ratio of the flexural stiffness of a beam section to the flexural stiffness of a width of slab bounded laterally by centerlines of adjacent panels (see Section 13.6.1.6), and α_{fm} is the average value of α_f for all beams on the edges of a panel. For two-way construction, ℓ_n is the clear span length in the long direction measured face-to-face of supports.

When two-way slab systems are supported directly on columns, shear around the columns is critically important, especially at exterior slab-column connections where the total exterior slab moment must be transferred directly to the column. Minimum slab thickness for flat plates often is governed by this condition.

Once the depth of a beam has been computed, the width b_w can be determined based on moment strength. The following equation, which is derived in the PCA's Simplified

Design (EB104) Handbook, can be used to determine b_w for the typical case when $f'_c = 4,000$ pounds per square inch (psi) and $f_y = 60$ kips per square inch (ksi):

$$b_w = 20 M_u / d^2$$

In this equation, M_u is the largest factored moment along the span (foot-kips) and d is the required effective depth of the beam (inches), based on deflection criteria. For beams with one layer of reinforcement, d can be taken equal to $h - 2.5$ inches, while for joists and slabs, d can be taken as $h - 1.25$ inches. Similar sizing equations can be derived for other concrete strengths and grades of reinforcement.

In the preliminary design stage, it is important for the engineer to consider fire resistance. Building codes regulate the fire resistance of the various elements and assemblies of a building structure. Fire resistance must be considered when choosing a slab thickness. Table 721.2.2.1 in the International Code Council's 2003 International Building Code (IBC) contains minimum reinforced concrete slab thickness for fire-resistance ratings of one to four hours, based on the type of aggregate used in the concrete mix. In general, concrete member thickness required for structural purposes is usually adequate to provide at least a two-hour fire-resistance rating. Adequate cover to the reinforcing steel is required to protect it from the effects of fire. Cover thicknesses for reinforced concrete floor slabs and beams are given in IBC Tables 721.2.3(1) and 721.2.3(3), respectively. The minimum cover requirements in Section 7.7.1 of ACI

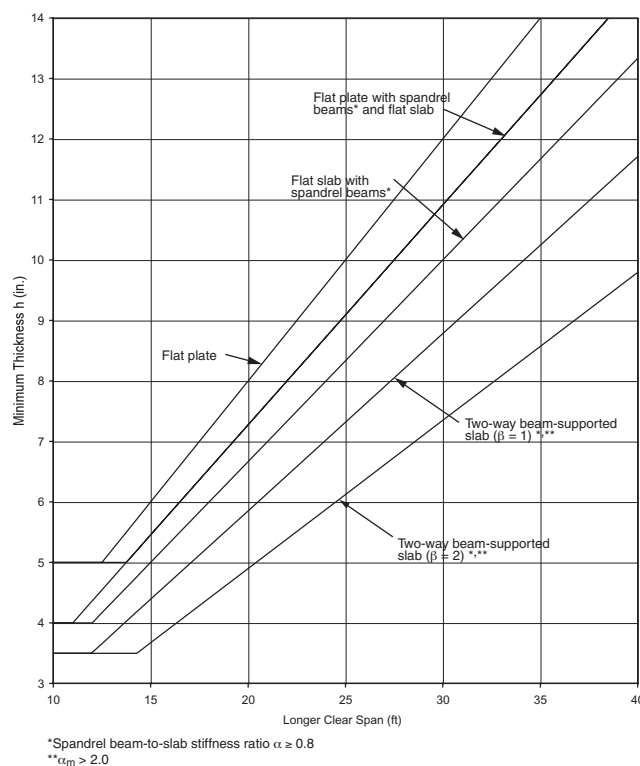

Figure 2: Minimum slab thickness for two-way slab systems

318-05 will provide at least a two-hour fire-resistance rating. In all cases, the local building code governing the specific project must be consulted to ensure that minimum fire-resistance requirements are met.

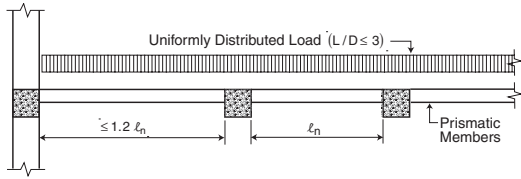

Figure 3: Conditions for analysis by coefficients of ACI Section 8.3.3

Analysis methods

Section 8.3 contains criteria for analyzing continuous beams and one-way slabs. In general, all members of frames or continuous construction must be designed for the maximum effects of factored loads, per Section 9.2, using an elastic analysis. Even though numerous computer programs exist that can accomplish this task, the set of approximate coefficients in Section 8.3.3 can be used to determine moments and shear forces, provided the limitations in Figure 3 are satisfied. These coefficients, which are given in Figure 4, provide a quick and conservative way of determining design forces for beams and one-way slabs, and can be used to check output from a computer program.

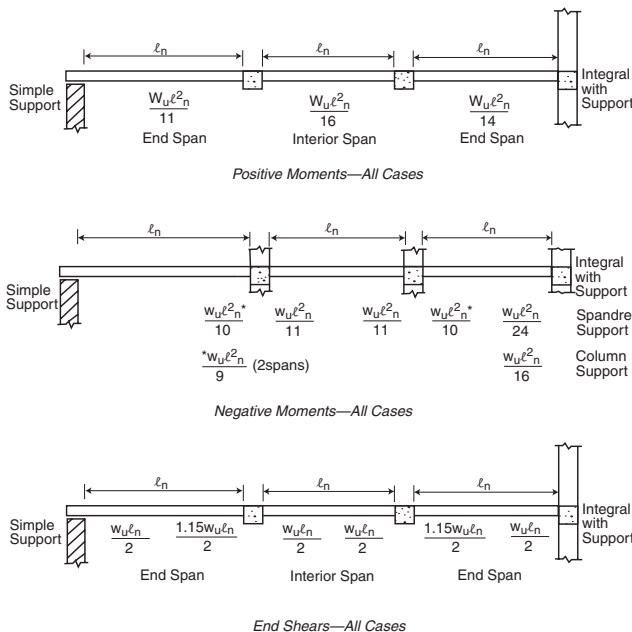

Figure 4: Analysis by coefficients of ACI Section 8.3.3

In lieu of an analysis procedure satisfying equilibrium and geometric compatibility, the Direct Design Method of Section 13.6 or the Equivalent Frame Method of Section 13.7 can be used to obtain design moments for two-way slab

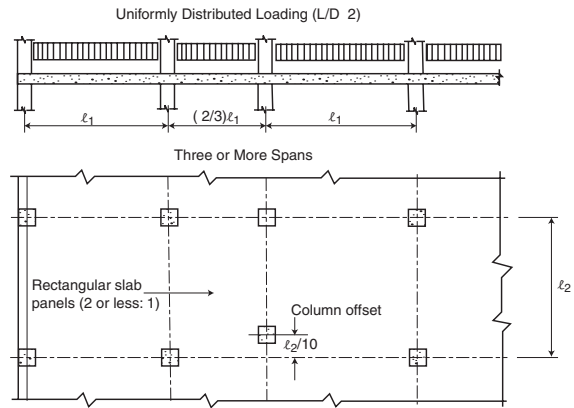

Figure 5: Conditions for analysis by the Direct Design Method

systems. If the limitations of the Direct Design Method in Section 13.6.1 are met (see Figure 5), then the total factored static moment M_o for a span can be distributed as negative and positive moments in the column and middle strips in accordance with Sections 13.6.3, 13.6.4, and 13.6.6, where

$$M_o = \frac{q_u \ell_2 \ell_n^2}{8}$$

And q_u = factored load per unit area; ℓ_2 = length of span, measured center-to-center of supports, in the direction perpendicular to the direction moments are being determined; and ℓ_n = length of clear span, measured face-to-face of supports, in the direction moments are being determined (Section 13.6.2.5).

Flat Plate or Flat Slab Supported Directly on Columns

Slab Moments	End Span		Interior Span		
	1 Exterior Negative	2 Positive	3 First Interior Negative	4 Positive	5 Interior Negative
Total Moment	0.26 M_o	0.52 M_o	0.70 M_o	0.35 M_o	0.65 M_o
Column Strip	0.26 M_o	0.31 M_o	0.53 M_o	0.21 M_o	0.49 M_o
Middle Strip	0	0.21 M_o	0.17 M_o	0.14 M_o	0.16 M_o

Note: All negative moments are at face of support.

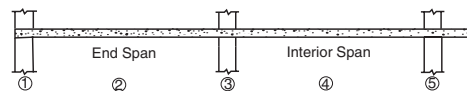

Figure 6: Design moment coefficients used with the Direct Design Method for flat plates or flat slabs supported directly on columns

Figures 6 and 7 summarize the moments in the column and middle strips along the span of flat plates or flat slabs supported directly on columns and flat plates or flat slabs with spandrel beams, respectively.

Design for flexure

The required amount of flexural reinforcement is calculated using the design assumptions of Section 10.2 and the



Flat Plate or Flat Slab with Spandrel Beams

Slab Moments	End Span			Interior Span	
	1 Exterior Negative	2 Positive	3 First Interior Negative	4 Positive	5 Interior Negative
Total Moment	0.30 M_o	0.50 M_o	0.70 M_o	0.35 M_o	0.65 M_o
Column Strip	0.23 M_o	0.30 M_o	0.53 M_o	0.21 M_o	0.49 M_o
Middle Strip	0.07 M_o	0.20 M_o	0.17 M_o	0.14 M_o	0.16 M_o

Note: (1) All negative moments are at face of support.
 (2) Torsional stiffness of spandrel beams $\beta_t \geq 2.5$. For values of β_t less than 2.5, exterior negative column strip moment increases to $(0.30 + 0.03\beta_t) M_o$.

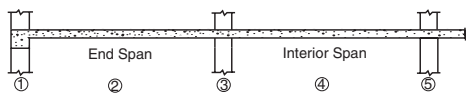

Figure 7: Design moment coefficients used with the Direct Design Method for flat plates or flat slabs with spandrel beams

general principles and requirements of Section 10.3, based on the factored moments from the analysis. In typical cases, beams, one-way slabs, and two-way slabs will be tension-controlled sections, so that the strength reduction factor ϕ is equal to 0.9 in accordance with Section 9.3. In such cases, the required amount of flexural reinforcement A_s at a section can be determined from the following equation, which is derived in PCA's Simplified Design for $f'_c = 4,000$ psi and $f_y = 60$ ksi:

$$A_s = \frac{M_u}{4d}$$

where M_u is the factored bending moment at the section (foot-kips) and d is the distance from the extreme compression fiber to the centroid of the longitudinal tension reinforcement (inches). For greater concrete strengths, this equation yields slightly conservative results. The required A_s must be greater than or equal to the minimum area of steel and less than or equal to the maximum area of steel.

For beams, the minimum area of steel $A_{s, \min}$ is given in Section 10.5.1:

$$A_{s, \min} = \frac{3\sqrt{f'_c} b_w d}{f_y} \geq \frac{200 b_w d}{f_y}$$

The equation for $A_{s, \min}$ need not be satisfied where the provided A_s at every section is greater than one-third that required by analysis.

For one-way slabs, $A_{s, \min}$ in the direction of the span is the same as the minimum area of steel for shrinkage and temperature reinforcement, which is $0.0216h$ per foot width of slab for Grade 60 reinforcement (Section 10.5.4). The maximum spacing of the reinforcement is $3h$ or 18 inches, whichever is less.

For two-way slabs, the minimum reinforcement ratio in each direction is 0.0018 for Grade 60 reinforcement (Section 13.3). In this case, the maximum spacing is $2h$ or 18 inches.

A maximum reinforcement ratio for beams and slabs is not directly given in ACI 318-05. Instead, Section 10.3.5 requires that nonprestressed flexural members must be designed such that the net tensile strain in the extreme layer of longitudinal

tension steel at nominal strength ϵ_t is greater than or equal to 0.004. In essence, this requirement limits the amount of flexural reinforcement that can be provided at a section. Using a strain compatibility analysis for 4,000-psi concrete and Grade 60 reinforcement, the maximum reinforcement ratio is 0.0206.

When selecting bar sizes, it is important to consider the minimum and maximum number of reinforcing bars that are permitted in a cross-section. The limits are a function of the following requirements for cover and spacing:

- Sections 7.6.1 and 3.3.2 (minimum spacing for concrete placement);
- Section 7.7.1 (minimum cover for protection of reinforcement); and
- Section 10.6 (maximum spacing for control of flexural cracking).

The maximum spacing of reinforcing bars is limited to the value given by Equation (10-4) in Section 10.6.4. The following equation can be used to determine the minimum number of bars n_{\min} required in a single layer:

$$n_{\min} = \frac{b_w - 2(c_c + 0.5d_b)}{s} + 1$$

The bar spacing s is given by Equation (10-4):

$$s = 15 \left(\frac{40,000}{f_s} \right) - 2.5c_c \leq 12 \left(\frac{40,000}{f_s} \right)$$

In these equations, c_c is the least distance from the surface of the reinforcement to the tension face of the section, d_b is the nominal diameter of the reinforcing bar, and f_s is the calculated tensile stress in the reinforcement at service loads, which can be taken equal to $2f_y/3$. The values obtained from the above equation for n_{\min} should be rounded up to the next whole number.

The maximum number of bars n_{\max} permitted in a section can be computed from the following equation:

$$n_{\max} = \frac{b_w - 2(c_s + d_s + r)}{(\text{Minimum clear space}) + d_b} + 1$$

where c_s = clear cover to the stirrups; d_s = diameter of stirrup reinforcing bar; $r = 0.75$ inch for No. 3 stirrups, or 1.0 inch for No. 4 stirrups; and clear space is the largest of 1 inch, d_b , or 1.33 (maximum aggregate size).

Computed values of n_{\max} from this equation should be rounded down to the next whole number.

Design for shear

Design provisions for shear are given in Chapter 11. A summary of the one-way shear provisions is given in Table 1. These provisions are applicable to normal-weight concrete members subjected to shear and flexure only with Grade 60 shear reinforcement. The strength reduction factor $\phi = 0.75$ per Section 9.3.2 and $V_c = 2\sqrt{f'_c} b_w d$ per Equation (11-3).

Both one-way shear and two-way shear must be investigated in two-way floor systems.

One-way shear — Design for one-way shear, which rarely governs, consists of checking that the following equation is satisfied at critical sections located a distance d from the face of the support (see Figure 8):

$$V_u \leq \phi 2 \sqrt{f'_c} \ell d$$

where ℓ is equal to ℓ_1 or ℓ_2 and V_u is the corresponding shear force at the critical section.

Two-way shear — As noted previously, two-way or punching shear usually is more critical than one-way shear in slab systems supported directly on columns. As shown in Figure 8, the critical section for two-way action is at a distance of $d/2$ from edges or corners of columns, concentrated loads, reaction areas, and changes in slab thickness, such as edges of column capitals or drop panels. For nonprestressed slabs of normal-weight concrete without shear reinforcement, the following must be satisfied (Section 11.12.2):

$$v_u \leq \phi v_c = \text{smallest of } \begin{cases} \phi \left(2 + \frac{4}{\beta} \right) \sqrt{f'_c} \\ \phi \left(\frac{\alpha_s d}{b_o} + 2 \right) \sqrt{f'_c} \\ \phi 4 \sqrt{f'_c} \end{cases}$$

where v_u is the maximum factored shear stress at the critical section and all other variables are defined in Chapter 2.

Moment transfer — Transfer of moment in slab-column connections takes place by a combination of flexure (Section 13.5.3) and eccentricity of shear (Section 11.12.6). The portion of total unbalanced moment M_u transferred by flexure is $\gamma_f M_u$ where γ_f is defined in Equation (13-1) as a function of the critical section dimensions b_1 and b_2 . It is assumed that $\gamma_f M_u$ is transferred within an effective slab width equal to

Table 1: ACI 318-05 provisions for shear design

		$V_u \leq \phi V_c / 2$	$\phi V_c \geq V_u > \phi V_c / 2$	$V_u > \phi V_c$
Required area of stirrups, A_v	None	—	$\frac{0.75 \sqrt{f'_c} b_w s}{f_{yt}} \geq \frac{50 b_w s}{f_{yt}}$	$\frac{(V_u - \phi V_c) s}{\phi f_{yt} d}$
	Required	—	$\frac{A_v f_{yt}}{0.75 \sqrt{f'_c} b_w} \leq \frac{A_v f_{yt}}{50 b_w}$	$\frac{\phi A_v f_{yt} d}{V_u - \phi V_c}$
Stirrup spacing, s	Required	—	—	$d / 2 \leq 24$ inches for $(V_u - \phi V_c) \leq 4 \phi \sqrt{f'_c} b_w d$
	Maximum	—	$d / 2 \leq 24$ inches	$d / 4 \leq 12$ inches for $(V_u - \phi V_c) > 4 \phi \sqrt{f'_c} b_w d$

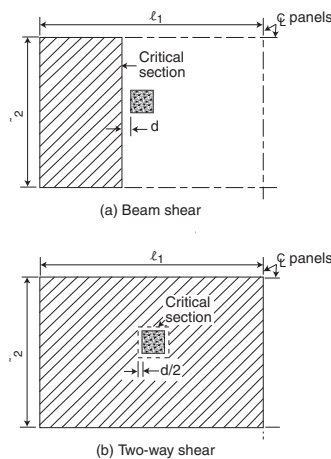

Figure 8: Critical sections for one-way and two-way shear

$c_2 + 1.5$ (slab or drop panel thickness on each side of the column or capital). Reinforcement is concentrated in the effective slab width such that $\phi M_n \geq \gamma_f M_u$.

The portion of M_u transferred by eccentricity of shear is $\gamma_v M_u = (1 - \gamma_f) M_u$ (Sections 13.5.3.1 and 11.12.6). When the Direct Design Method is used, the gravity load moment M_u to be transferred between slab and edge column must be $0.3 M_o$ (Section 13.6.3.6).

The factored shear forces on the faces of the critical section AB and CD are as follows (Section 11.12.6.2):

$$v_u(AB) = \frac{V_u}{A_c} + \frac{\gamma_v M_u c_{AB}}{J_c}$$

$$v_u(CD) = \frac{V_u}{A_c} - \frac{\gamma_v M_u c_{CD}}{J_c}$$

where A_c is the area of the critical section and J_c / c_{AB} and J_c / c_{CD} are the section moduli of the critical section. Numerous resources are available that give equations for A_c , J_c / c_{AB} , and J_c / c_{CD} , including PCA's Simplified Design.

Summary

The above discussion summarized the design requirements of concrete floor systems with nonprestressed reinforcement according to ACI 318-05. It is important to note that once the required flexure and shear reinforcement have been determined, the reinforcing bars must be developed properly in accordance with the provisions in Chapters 12 and 13. The structural integrity requirements of Section 7.13 must be satisfied as well.

Detailed, worked-out example problems that illustrate the material presented in this paper can be found on the PCA web site at www.cement.org/buildings/design_aids.asp. ■

David A. Fanella, Ph.D., S.E., P.E., is project manager, Graef, Anhalt, Schloemer & Associates, Inc., Chicago. He can be contacted via e-mail at david.a.fanella@gasai.com. **Iyad M. Alsamsam, Ph.D., S.E., P.E.**, is manager, Buildings and Special Structures, Portland Cement Association, Skokie, Ill. He can be contacted via e-mail at alsamsam@cement.org.



Professional Development Series Sponsor: Portland Cement Association



Concrete Thinking
for a sustainable world



Portland Cement Association

5420 Old Orchard Road, Skokie, IL 60077

(847) 972-9058 • Fax: (847) 972-9059 • Email: info@cement.org • www.cement.org

Questions

1. Problem 1: A five-span continuous reinforced concrete beam has exterior spans equal to 30 feet and interior spans of 25 feet. All spans are measured center-to-center of supports. Exterior columns are 20 x 20 inches and interior columns are 24 x 24 inches. The beam supports a service dead load of 3,250 pounds per linear foot (plf) and a service live load of 2,000 plf. Neglect the weight of the beam. Concrete is normal-weight with $f'_c = 4,000$ pounds per square inch (psi), and reinforcing steel is Grade 60, $f_y = 60$ kips per square inch (ksi). The minimum beam depth that would satisfy the deflection criteria of Section 9.5 for all spans is nearest to

- a) 16 inches b) 17 inches c) 20 inches d) 22 inches

2. For the system described in Problem 1, assume a beam depth of 24 inches. The minimum width of the beam that can be used for all spans based on moment strength is nearest to

- a) 16 inches b) 20 inches c) 22 inches d) 24 inches

3. For the system described in Problem 1, assume a 28-inch-wide by 24-inch-deep beam. The required area of negative flexural reinforcement required at the supports of the middle span is nearest to

- a) 2.50 inches² b) 3.00 inches² c) 3.25 inches² d) 4.0 inches²

4. For the system described in Problem 1, assume a 24-inch-wide by 22-inch-deep beam. Using No. 4 U-stirrups, the required spacing of the stirrups at the critical section of the first interior support is nearest to

- a) 5.0 inches b) 6.0 inches c) 8.0 inches d) 10.0 inches

5. The exterior panel of a concrete floor system consisting of a slab with beams spanning between the supports on all sides has center-to-center spans of 22 feet and 25 feet. It is supported by columns that are 22 x 22 inches. All beams are 22 inches wide by 24 inches deep. Preliminary design indicates that the beam-to-slab flexural stiffness ratios α_f for the

beams are 4.65, 5.23, 2.92, and 3.32. Assume Grade 60 reinforcement ($f_y = 60$ ksi). The minimum slab thickness that would satisfy the deflection criteria of Section 9.5.3 is nearest to

- a) 3.5 inches b) 5.0 inches c) 6.0 inches d) 7.0 inches

6. Problem 6: The interior panel of a flat plate floor system has center-to-center span lengths of 20 feet and 18 feet. Columns are 20 x 20 inches. Assume normal-weight concrete with $f'_c = 4,000$ psi and Grade 60 reinforcement. Use a preliminary slab thickness of 7.5 inches (effective $d = 6.25$ inches). Superimposed dead load = 20 pounds per square foot (psf), and service live load = 40 psf. The factored, one-way shear force V_u at the critical section of a 1-foot-wide design strip is nearest to

- a) 1.7 kips b) 2.5 kips c) 5.3 kips d) 20.4 kips

7. For the system described in Problem 6, the factored, two-way shear force V_u at the critical section of an interior column is nearest to

- a) 50.5 kips b) 71.0 kips c) 85.6 kips d) 99.4 kips

8. For the system described in Problem 6, the allowable two-way shear force ϕV_c is nearest to

- a) 75.5 kips b) 85.3 kips c) 94.2 kips d) 124.5 kips

9. For the system described in Problem 6, it has been determined that the Direct Design Method of Section 13.6 can be used. For a design strip along the 20-foot span direction ($\ell_1 = 20$ feet), the total factored static moment M_o is nearest to

- a) 151 ft-kips b) 175 ft-kips c) 199 ft-kips d) 225 ft-kips

10. For the system described in Problem 6, the required area of flexural reinforcement in the column strip at an interior support in an interior span is nearest to

- a) 1.5 inches² b) 1.9 inches² c) 2.2 inches² d) 3.0 inches²

Structural Engineer's Professional Development Series Reporting Form

Article Title: Design of Reinforced Concrete Floor Systems

Sponsor: Portland Cement Association

Valid for credit until: September 2007

Instructions: Select one answer for each quiz question and clearly circle the appropriate letter. Provide all of the requested contact information. Fax this Reporting Form to (847) 972-9059. (You do not need to send the Quiz; only this Reporting Form is necessary to be submitted.)

- | | |
|------------------------------------|------------------------------------|
| 1) a b c d | 6) a b c d |
| 2) a b c d | 7) a b c d |
| 3) a b c d | 8) a b c d |
| 4) a b c d | 9) a b c d |
| 5) a b c d | 10) a b c d |

Required contact information

Last Name: _____ First Name: _____ Middle Initial: _____

Title: _____ Firm Name: _____

Address: _____

City: _____ State: _____ Zip: _____

Telephone: _____ Fax: _____ E-mail: _____

Certification of ethical completion: I certify that I read the article, understood the learning objectives, and completed the quiz questions to the best of my ability. Additionally, the contact information provided above is true and accurate.

Signature: _____ Date: _____